

## **Preface**

STRONG reserves the right to revise this publication and to make changes to the content within without obligation to provide notification.

STRONG reserves the right to make improvements to the design and functionality of the product.

For the latest product details and firmware versions please refer to STRONG Website: [www.strong-eu.com](http://www.strong-eu.com) .

Trademarks ©STRONG 2024. All rights reserved. STRONG and the STRONG logo are the registered trademarks of STRONG.

This publication may not be reproduced in whole or in part without prior express written permission from STRONG.

Thank you for purchasing a STRONG internet protocol camera we hope you find the features available meet all your needs.

## Package content

The contents listed are for reference only, please refer to the actual packing list.



IP Camera



Quick Start Guide



Positioning Sticker



3x Dowels



Installation screws



Waterproof Kit

*Power supply not included*

## Appearance

\* Design subject to change

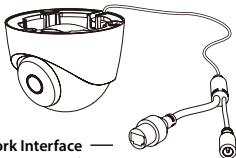

**Network Interface** —  
RJ45 (100M, POE)

**Power Interface** —  
DC12V/1A Power supply  
⊖ ⊕

## Installation

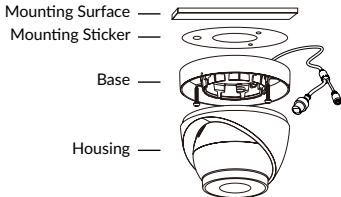

1. Fix the base with screw
2. Snap the housing into the base.

## Disassembly

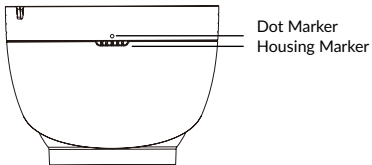

1. Rotating the housing to make the housing marker align the dot marker
2. Insert the screwdriver along the housing marker
3. Press down the screwdriver

## **Download and install the APP for IOS & Android devices**

Using the image below scan the QR code using your mobile device. The link will take you to the Apple APP or Google Play Store where you will find "Vision by STRONG". Alternatively visit the Apple APP or Google Play Store and search for "Vision by STRONG". Download the APP onto your Apple or Android device.



## First Time Camera Installation

- Open up the “Vision by STRONG” APP on your mobile device.
- Scroll down and select your Country
- You will now see a “Signing Up” page.
- If this is your first time install AND you do not have an account then follow these steps
  - 1. Enter your email address on the top line.
  - 2. Once entered select “SEND” on the second line and wait for a one time code to be sent to your email address.
  - 3. Once you have received the code, please enter it on the second line of the sign in page.
  - 4. Please tick the box to acknowledge you have read the USER SERVICE AGREEMENT.
  - 5. Click NEXT
- You will now be asked to enter a secure password and then retype it to confirm. Follow the onscreen instructions and click “CONFIRM”.



- You will need to record and keep this password safe as it will be needed for future use of the APP.
- The next screen you see will be the account login screen.
- Enter your email address and your newly created password.



- Remove the camera from the packaging.
- To connect the camera:
- With a POE power supply, connect the camera directly to the NVR
  - Or plug the PSU into the mains and connect the camera to the PSU. Connect the camera to the internet via a router/switch or NVR.
  - In the APP select “ADD A DEVICE” and follow the instructions.



*\*Power supply not included*



- Once completed you will be asked to choose a name for your camera.
- Once done select «COMPLETE».

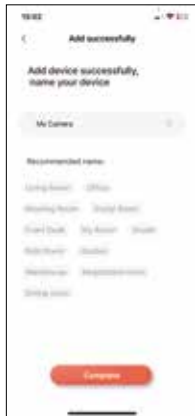

- You are now able to access all the features the camera has to offer.



# Connect to the NVR

## 1. Connection

Connect the camera(s) and the NVR to the same LAN (Local Area Network), see below for the basic topology diagrams.

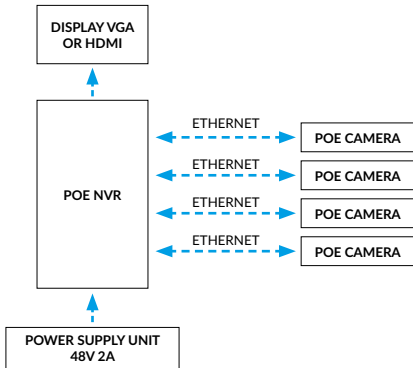

## 2. Check Video

The monitor will show the live view of the camera(s) after the devices are correctly deployed.

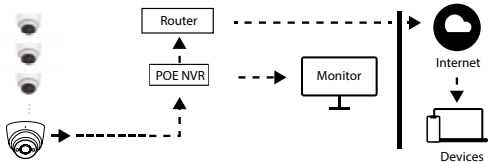

\*This figure is for reference only. Please refer to the actual application interface.

## Recording To The Cloud

Your camera has the capability to record and store video in the cloud. To use this feature, follow the instructions below.

In the «My Camera» screen select «Cloud»



Select «subscribe now»



Select «Order»



Choose your preferred storage plan and proceed to check out



## Specification

Product Name	DUAL-LIGHT TURRET CAMERA
MODEL	TURRET-45D-5MP-UK
Power Supply	DC 12V $\equiv$ 1A or POE 48V $\equiv$ 0.35A
Environment	Working Temp -30°C~60°C Humidity: <90% Storage Temp -40°C ~60°C Humidity: < 95%

This product is sold without power supply adapter.

## Warranty

The product is guaranteed for 2 years from the original purchase date:  
In case of any product failure during the warranty period, please contact our after-sales service.

1. Please return the completed warranty card in time, to ensure the best aftersales service we can offer in the event the device fails.
2. The information on your warranty card will be used for repair, please fill it in carefully.
3. Warranty is not applicable in the following cases:
  - Failure caused by man-made reasons.
  - Failure caused by improper usage.
  - Failures caused by operating the product outside its environmental limits.
  - Product damage caused by a force majeure event.
  - There is no product serial number or warranty card, or the product serial number and label is indistinguishable or damaged.

## Warning

- Please use this product under the the electrical safety regulations of the country and applicable regions.
- Please use the power supply that meets SELV requirements.
- Please make sure the product is firmly installed on the wall or ceiling.

## Notes

- If the product is not working properly, please contact the dealer or the nearest service centre, and do not disassemble or modify the product in any way. (We will not take any responsibility for the problems caused by unconfirmed modification or maintenance).
- Do not install the product outdoors unless it is sheltered and protected from adverse weather conditions.
- Do not install the product where it may come into contact with water or corrosive products.
- Please avoid installing the product in a vibration or shock environment and keep the product away from electromagnetic interference.
- Avoid placing the product in direct sunlight.
- Operate the camera within the environmental limits set out in this QSG.
- Avoid pointing the lens directly into strong light as this may damage the camera.
- Ensure there is good ventilation around the camera.
- Do not touch the lens directly. If you need to clean it, please slightly dampen a soft cloth with alcohol and gently wipe off the dust.



- Please keep all the original packaging materials of the product properly. If there is any problem, please use the packaging materials to pack the product and send it to the agent or return it to the manufacturer for treatment. We cannot accept accidental damage in transport caused by non-original packaging materials.



Correct Disposal of this product. This marking indicates that this product should not be disposed with other household wastes through out EU & UK. To prevent possible harm to the environment or human health from uncontrolled waste disposal, recycle it responsibly to promote the sustainable reuse of material resources. To return your used device,

please use the return and collection systems or contact the retailer where the product was purchased. They can take this product for environmental safe recycling.

## DECLARATION OF CONFORMITY

The full text of the EU/UK declaration of conformity is available at the following internet address: <https://www.strong-eu.com/downloads/>

This product is in conformity with the Product Security  
and Telecommunications Infrastructure Act 2022.

Scan below for full statement

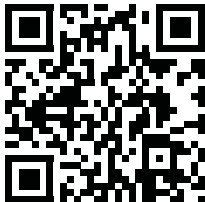

[eu.strong-eu.com/psti-compliance/](https://www.strong-eu.com/psti-compliance/)